

PERFORMANCE TEST REPORT

Rendered to:

BAMCO INC.

PRODUCT TYPE: ACM Wall Panel Systems

Summary of Results		
Title	Test Specimen #1	Test Specimen #2
Air Infiltration	<0.01 cfm/ft ²	N/A
Water Resistance Test Pressure	15.05 psf	N/A
Uniform Load Deflection Test Pressure	N/A	+100.0 psf / -110.0 psf
Uniform Structural Load Test Pressure	N/A	+130.0 psf / -160.0 psf

This report contains in its entirety:

Cover Page: 1 Page
 Report Body: 6 Pages
 Test Equipment: 1 Page
 Photographs: 2 Pages
 Drawings: 5 Pages

Report No.: 91674.01-109-44
Test Dates: 05/26/09
Through: 03/26/10
Report Date: 05/05/10
Expiration Date: 03/26/14

PERFORMANCE TEST REPORT

Rendered to:

BAMCO INC.
30 Baekeland Avenue
Middlesex, New Jersey 08846

Report No.: 91674.01-109-44
Test Dates: 05/26/09
Through: 03/26/10
Report Date: 05/05/10
Expiration Date: 03/26/14

Project Summary: Architectural Testing, Inc. was contracted by Bamco Inc. to perform testing on two ACM wall panel systems. Test specimen descriptions and results are reported herein. The samples were provided by the client.

Test Methods: The test specimens were evaluated in accordance with the following:

ASTM E 283-04, Test Method for Determining Rate of Airflow Through Exterior Windows, Curtain Walls and Doors Under Specified Pressure Differences Across the Specimen.

ASTM E 330-02, Test Method for Structural Performance of Exterior Windows, Curtain Walls and Doors by Uniform Static Air Pressure Difference.

ASTM E 331-00, Test Method for Water Penetration of Exterior Windows, Curtain Walls and Doors by Uniform Static Air Pressure Difference.

Test Specimen Description:

Product Type: ACM Wall Panel Systems

Test Specimen #1:

Overall Size: 8' 0" wide by 8' 0" high

Panel Size (4): 4' 0" wide by 4' 0" high

Overall Area: 64.00 ft²

Test Specimen Description: (Continued)

Test Specimen #2:

Overall Size: 14' 0" wide by 7' 0" high

Center Panel Size: 12' 0" wide by 5' 0" high

Corner Panel Size (4): 1' 0" wide by 1' 0" high

Center Side Panel Size (2): 1' 0" wide by 5' 0" high

Center Top and Bottom Panel Size (2): 12' 0" wide by 1' 0" high

Overall Area: 98 ft²

The following descriptions apply to all specimens.

Finish: All aluminum panels were painted.

Panel Construction: The panels were 4 mm thick composite aluminum, fabricated from two 1/32" thick aluminum skins and a plastic core. The panel edges were routed and returned to form a 90° angle and a 1" long leg. The panels utilized an extruded aluminum panel bar (reference Part #GX-5100) along the returned edge of the panel (reference Drawing #SK-D-1D). The aluminum panel bar was secured to the leg of panels with 1/8" diameter rivets located 1-1/2" from each corner and spaced 16" on center. The corners of the panel bars utilized a 0.045" thick aluminum triangle piece and secured with a #10 x 3/4" long hex head self-tapping screw per side. The aluminum panel bars were placed into an extruded aluminum mounting bar (reference Drawing #SK-D-3D, Part #GX-5200). The mounting bars were secured to the panel bars with #10 x 3/4" long hex head self-tapping screws located 3" from each end and spaced 16" on center. The base of the wall utilized an extruded aluminum flashing (reference Part #GX-5400) along the length of the bottom of the wall secured with #10 x 1-1/2" long hex head self-tapping screws, one per stud (reference Drawing #SK-D-4D). The horizontal and vertical joints utilized a Kerf-mounted silicone gasket with dual-leaves set in a bed of sealant.

Test Wall: The test wall was fabricated with 2x6, 16 gauge galvanized steel studs with a Spruce-Pine-Fir wood wrap around the perimeter. The studs were sheathed with 5/8" thick DensGlass™ which was secured to the studs with #6 x 1-1/4" self-tapping screws, spaced 24" on center. The exterior of the DensGlass™ was covered with a DuPont Tyvek™ air-water barrier. The perimeter and seams of the air-water barrier was sealed with DuPont Tyvek Tape™.

Test Specimen Description: (Continued)

Installation: The mounting bars were secured to 0.060" thick steel hat channels with #10 x 1-1/2" long hex head self-tapping screws located 1" from each end and spaced 16" on center. The hat channels were secured to the steel studded wall with #10 x 1-1/2" long hex head self-tapping screws located 1" from each end and spaced 16" on center through the DensGlass™ and air-water barrier. The perimeter of the hat channels were sealed with silicone at fastener penetrations. The exterior perimeter was sealed with silicone.

Test Results: The temperature during testing was 74°F. The results are tabulated as follows:

<u>Test Method</u>	<u>Title of Test</u>	<u>Results</u>
<u>Test Specimen #1:</u>		
ASTM E 283	Air Infiltration	
	1.60 psf (25 mph)	<0.01 cfm/ft ²
	6.27 psf (50 mph)	<0.01 cfm/ft ²
ASTM E 331	Water Resistance	
	15.05 psf	No leakage
<u>Test Specimen #2:</u>		
ASTM E 330	Uniform Load Deflection	
	(Deflections reported were taken between the stiffeners)	
	(Loads were held for 10 seconds)	
	100.0 psf (positive)	0.74"
	110.0 psf (negative)	0.32"
ASTM E 330	Uniform Load Deflection	
	(Deflections reported were taken along the stiffeners)	
	(Loads were held for 10 seconds)	
	100.0 psf (positive)	0.68"
	110.0 psf (negative)	0.34"
ASTM E 330	Uniform Load Structural	
	(Permanent sets reported were taken between the stiffeners)	
	(Loads were held for 10 seconds)	
	130.0 psf (positive)	0.04"
	160.0 psf (negative)	0.01"

Test Results: (Continued)

<u>Test Method</u>	<u>Title of Test</u>	<u>Results</u>
<u>Test Specimen #2:</u> (Continued)		
ASTM E 330	Uniform Load Structural (Permanent sets reported were taken along the stiffeners) (Loads were held for 10 seconds)	
	130.0 psf (positive)	0.03"
	160.0 psf (negative)	0.02"

Note: 4-1/4" holes were drilled through the DensGlass™ and the air-water barrier to assist pressurization of the ACM panels.

General Note: All testing was performed in accordance with the referenced standards.

Tape and film were used to seal against air leakage during structural testing. In our opinion, the tape and film did not influence the results of the test.

Drawing Reference: The test specimen drawings have been reviewed by Architectural Testing and are representative of the test specimen reported herein.

List of Official Observers:

<u>Name</u>	<u>Company</u>
Ken R. Stough	Architectural Testing, Inc.
Aaron M. Shultz	Architectural Testing, Inc.
Jeremy R. Bender	Architectural Testing, Inc.
Emily C. Riley	Architectural Testing, Inc.
Eric M. Brennan	Architectural Testing, Inc.
Joseph A. Reed, P.E.	Architectural Testing, Inc.
Russell W. Clark	Architectural Testing, Inc.

Detailed drawings, data sheets, representative samples of test specimens, a copy of this report, or other pertinent project documentation will be retained by Architectural Testing, Inc. for a period of four years from the original test date. At the end of this retention period, such materials shall be discarded without notice and the service life of this report will expire.

Results obtained are tested values and were secured by using the designated test methods. If test specimen contains glazing, no conclusions of any kind regarding the adequacy or inadequacy of the glass in the test specimen can be made. This report does not constitute certification of this product nor an opinion or endorsement by this laboratory. It is the exclusive property of the client so named herein and relates only to the specimen(s) tested. This report may not be reproduced, except in full, without the written approval of Architectural Testing, Inc.

For ARCHITECTURAL TESTING, INC:

Russell W. Clark
Technician

Joseph A. Reed, P.E.
Director - Engineer and Product Testing

RWC:vlm

Attachments (pages): This report is complete only when all attachments listed are included.

- Appendix-A: Test Equipment (1)
- Appendix-B: Photographs (2)
- Appendix-C: Drawings (5)

Revision Log

<u>Rev. #</u>	<u>Date</u>	<u>Page(s)</u>	<u>Revision(s)</u>
0	05/05/10	N/A	Original report issue

Appendix A

Test Equipment

Instrument	Manufacturer	Asset #
Weather Station	Davis: Vantage Pro	Y003257
Control Panel	Architectural Testing, Inc.	5406
20" Liner Transducer	Celesco	4336
20" Liner Transducer	Celesco	3420
20" Liner Transducer	Celesco	62187
20" Liner Transducer	Celesco	Y003027
20" Liner Transducer	Celesco	62185
20" Liner Transducer	Celesco	Y002774
Control Panel	Architectural Testing, Inc.	3232
Spray Rack	Architectural Testing, Inc.	3956A
Spray Rack	Architectural Testing, Inc.	3956B

Appendix B

Photographs



Photo No. 1
Air Infiltration Test with Tare Bag



Photo No. 2
Water Penetration Test



Photo No. 3
Full System Structural Load Test Set-up

Appendix C

Drawings

2" X 10" WOOD FRAMING
TYP.

STIFFENER SPACING
@ 2'-0" TYPICAL

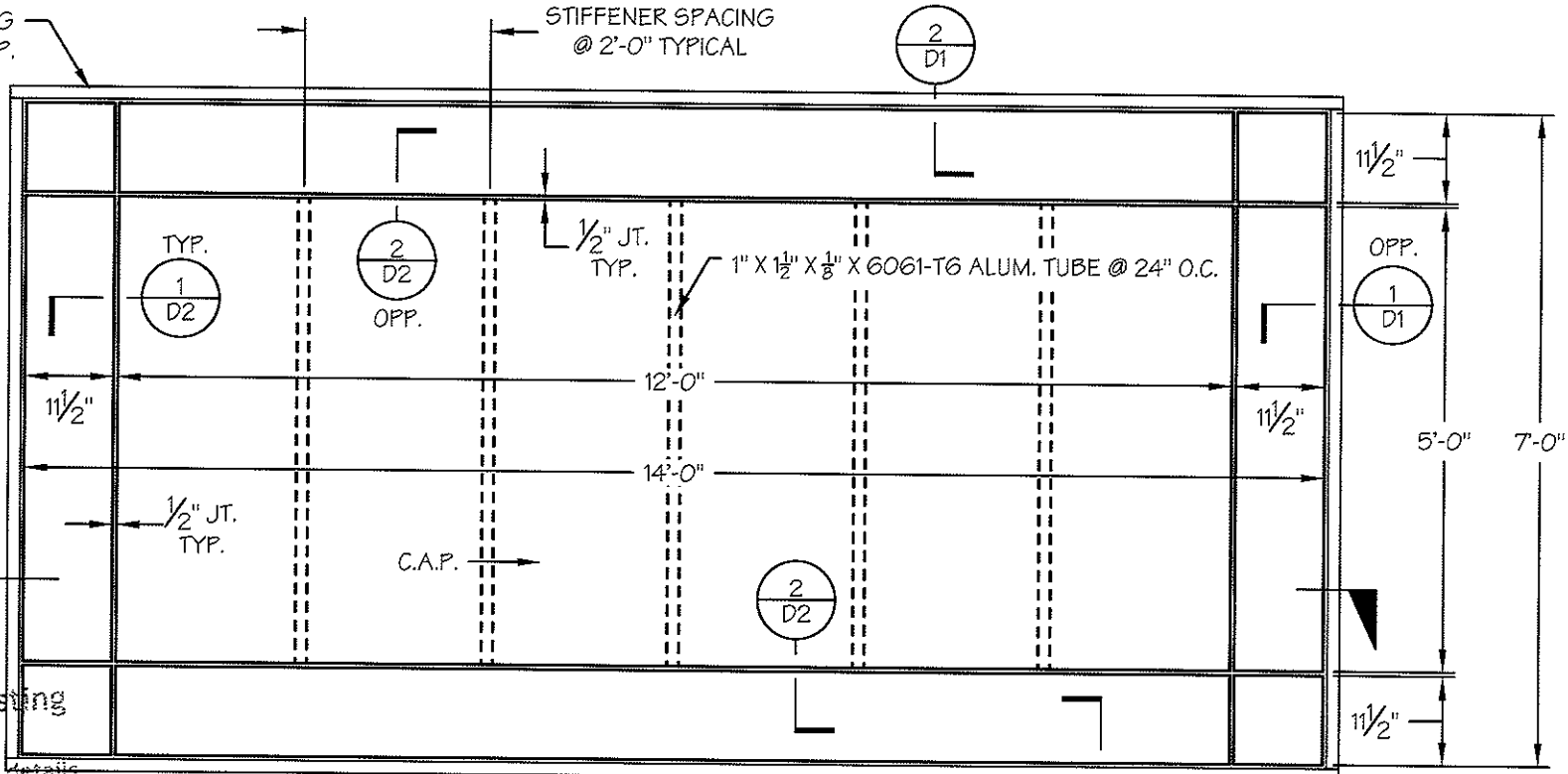

Test sample complies with these details.
Deviations are noted.

Report# 91674.01-109-44
Date 4/23/10
Tech R. Clark

1 ELEVATION G-500
FS-1 1/2" = 1'-0" Re: N/A

1 D3

1 D1

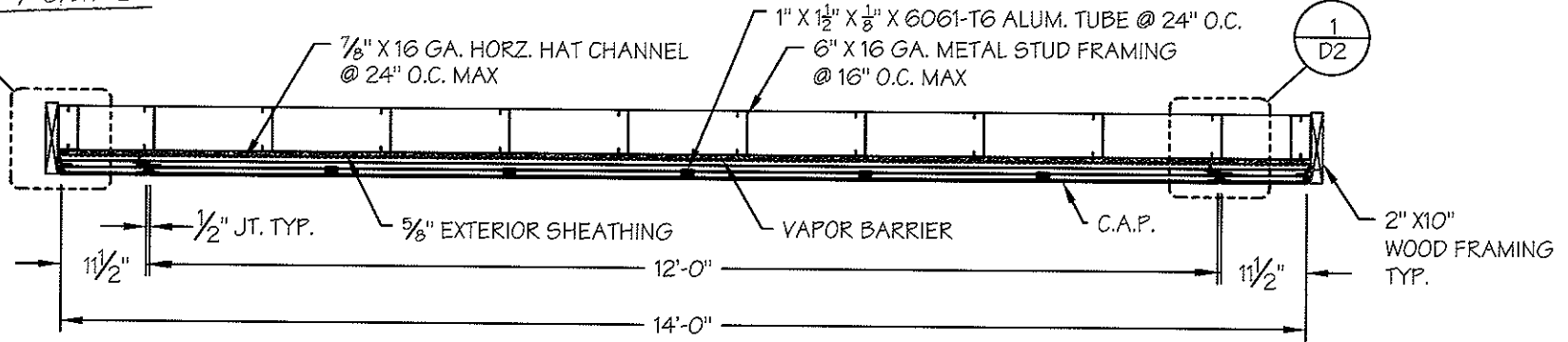

2 FLOOR PLAN G-500
FS-1 1/2" = 1'-0" Re: N/A

1 FS-1

STIFFENER TYPE & SPACING AS NOTED

7'-0" X 14'-0"
FULL SYSTEM TEST G-500

BAMCO inc.
PHONE: (732) 302-0889
FAX: (732) 302-9466
30 Paekeland Avenue, Middlesex, NJ 08846

Project Name/Address: FULL SYSTEM TEST 2009
General Contractor: FULL SYSTEM TEST G-500 GASKET SYSTEM
BAMCO Project No: Drawn By: PG Date: 09/09/09 Scale: 1/2" = 1'-0"

Drawing No.
SK-
FS-1

2" X 10" WOOD FRAMING
TYP.

Architectural Testing

Test sample complies with these details.
Deviations are noted.

Report # 91674.02-109-44

Date 12-17-09 Tech KS

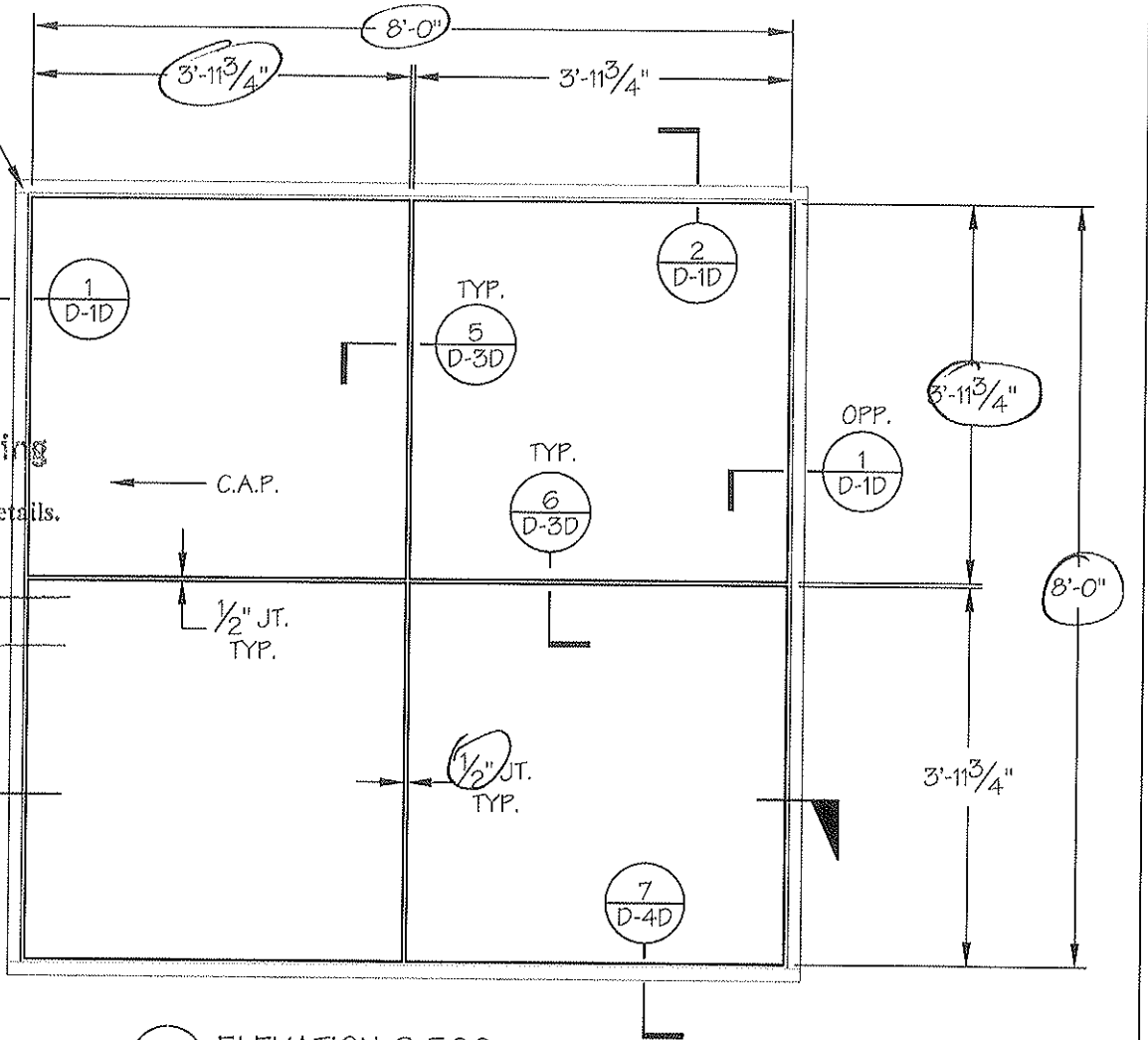

1 ELEVATION G-500
AW-2 1/2" = 1'-0" Re: N/A

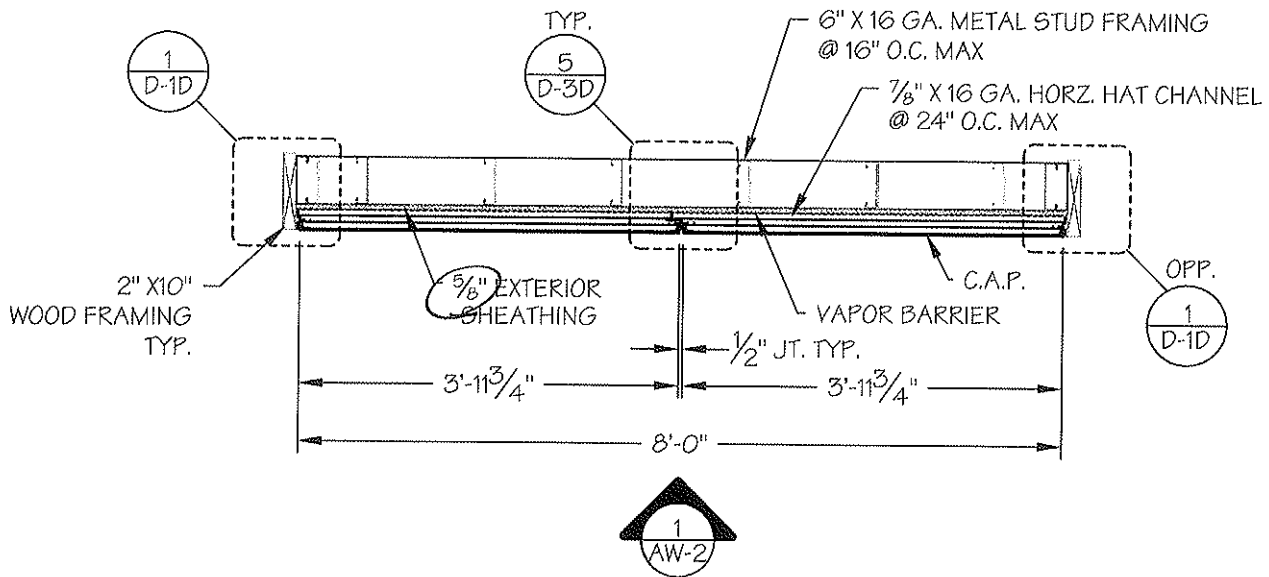

2 FLOOR PLAN G-500
AW-2 1/2" = 1'-0" Re: N/A

8'-0" X 8'-0" PAGE 2 OF 2
AIR & WATER TEST G-500

STIFFENER SPACING TO BE DETERMINED

BAMCO inc.

30 Backland Avenue, Middlesex, NJ 08846

PHONE: (732) 302-0889
FAX: (732) 302-9456

Project Name/Address: SYSTEM TEST 2009

General Contractor: AIR & WATER TEST G-500 GASKET SYSTEM

BAMCO Project No:

Drawn By: PMG

Date: 04/27/09

Scale: 1/2" = 1'-0"

Drawing No.

SK-

AW-2

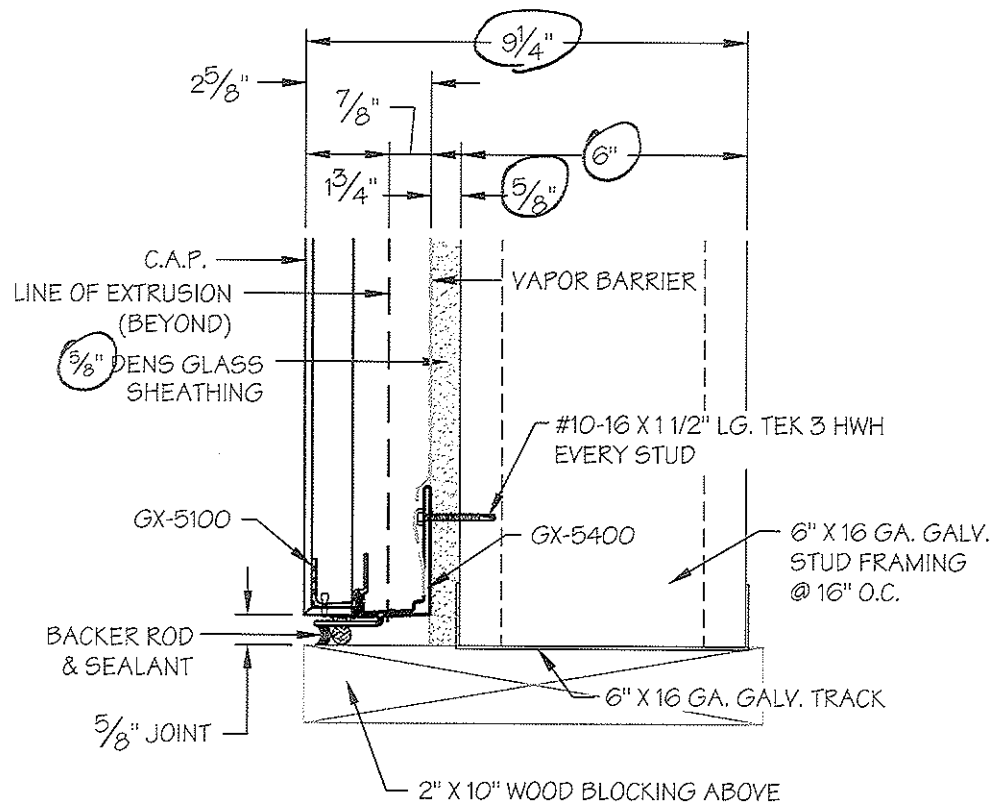

7 HORIZONTAL BASE TERMINATION
 D-4D 3" = 1'-0" Re: N/A

 Architectural Testing

Test sample complies with these details.
 Deviations are noted.

Report # 91674.02-109-44

Date 12-17-09 Tech KS

DETAILS - BASE TERM.	BAMCO inc.	PHONE: (732) 302-0889	Project Name/Address: SYSTEM TEST 2009		Drawing No. SK- D-4D
		FAX: (732) 302-8456	General Contractor: STANDARD DETAILS		
30 Backland Avenue, Middlesex, NJ 08846		BAMCO Project No:	Drawn By: PMG	Date: 04/27/09	Scale: 3"=1'-0"

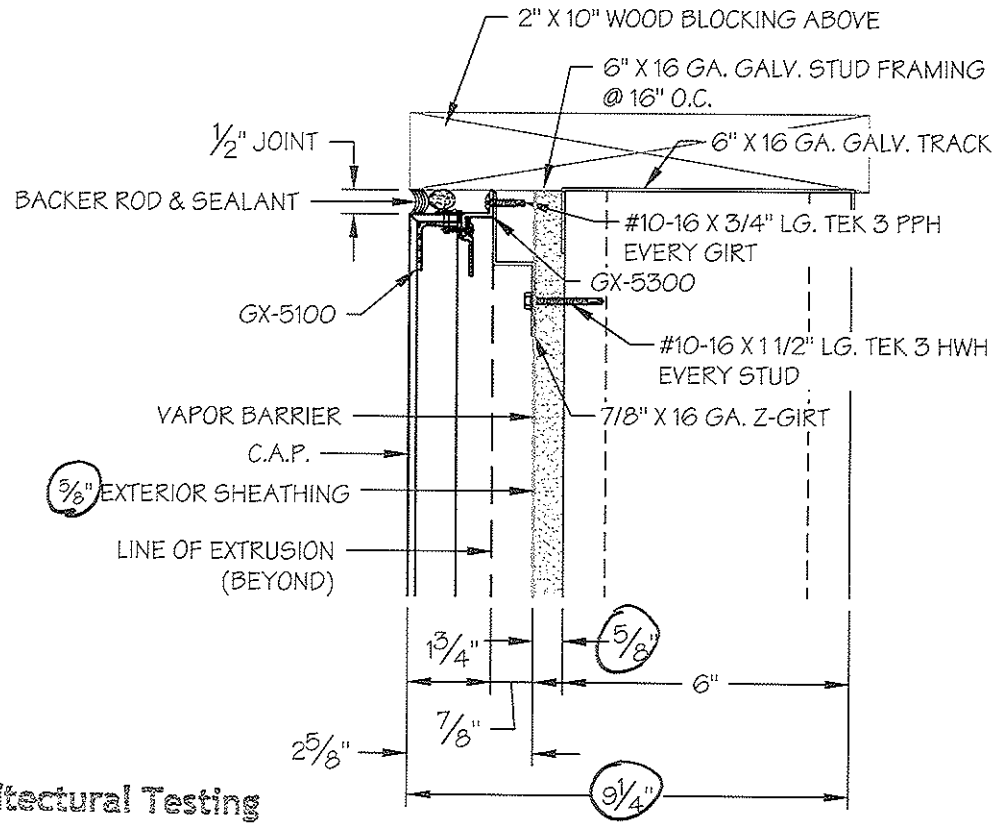
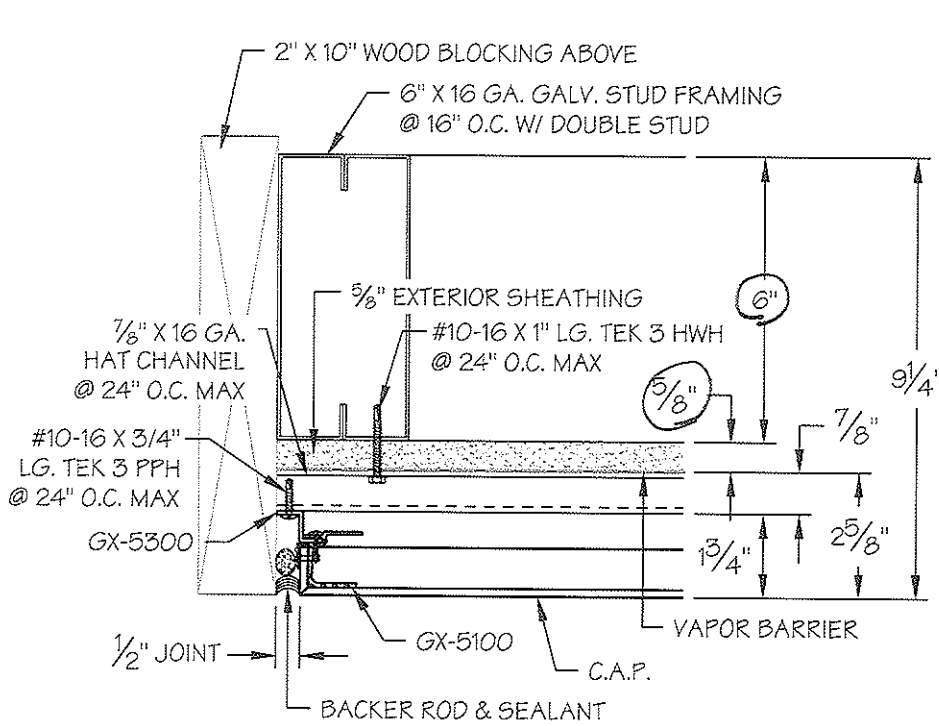

1 VERTICAL TERMINATION
 D-1D 3" = 1'-0" Re: N/A

2 HORIZONTAL TERMINATION
 D-1D 3" = 1'-0" Re: N/A

Architectural Testing
 Test sample complies with these details.
 Deviations are noted.
 Report # 91674.02-109-44
 Date 12-17-09 Tech KS

DETAILS - TERM.

BAMCO inc. PHONE: (732) 302-0889 FAX: (732) 302-9456
 30 Backland Avenue, Middlesex, NJ 08846

Project Name/Address: SYSTEM TEST 2009
 General Contractor: STANDARD DETAILS
 BAMCO Project No.: Drawn By: PMG Date: 04/27/09 Scale: 3" = 1'-0"

Drawing No.
 SK-
 D-1D

6" X 16 GA. GALV. STUD FRAMING
@ 16" O.C. MAX

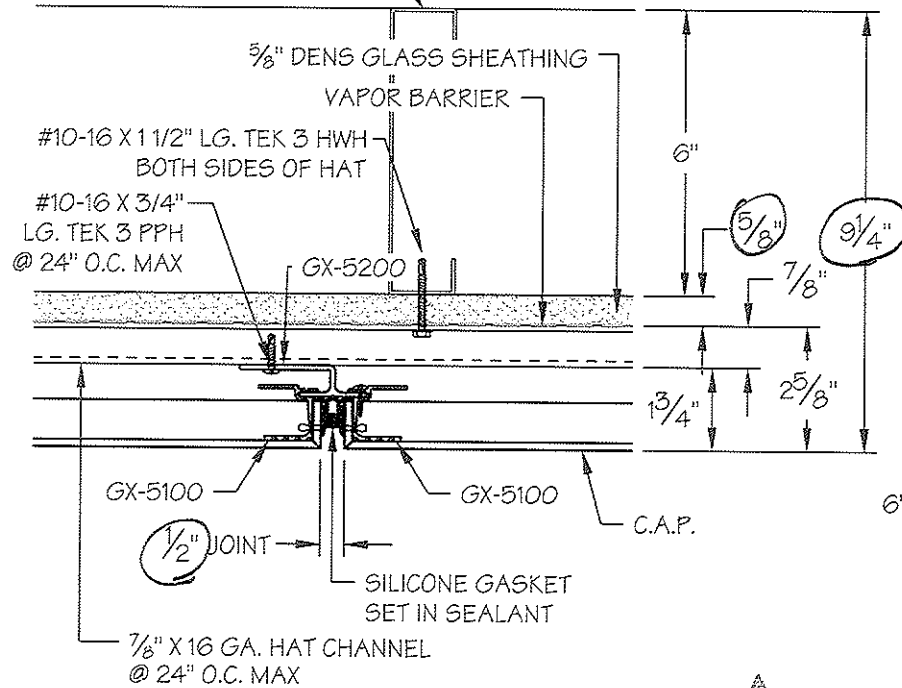

5 VERTICAL JOINT G-500
D-3D 3" = 1'-0" Re: N/A

VAPOR BARRIER
LINE OF EXTRUSION (BEYOND)

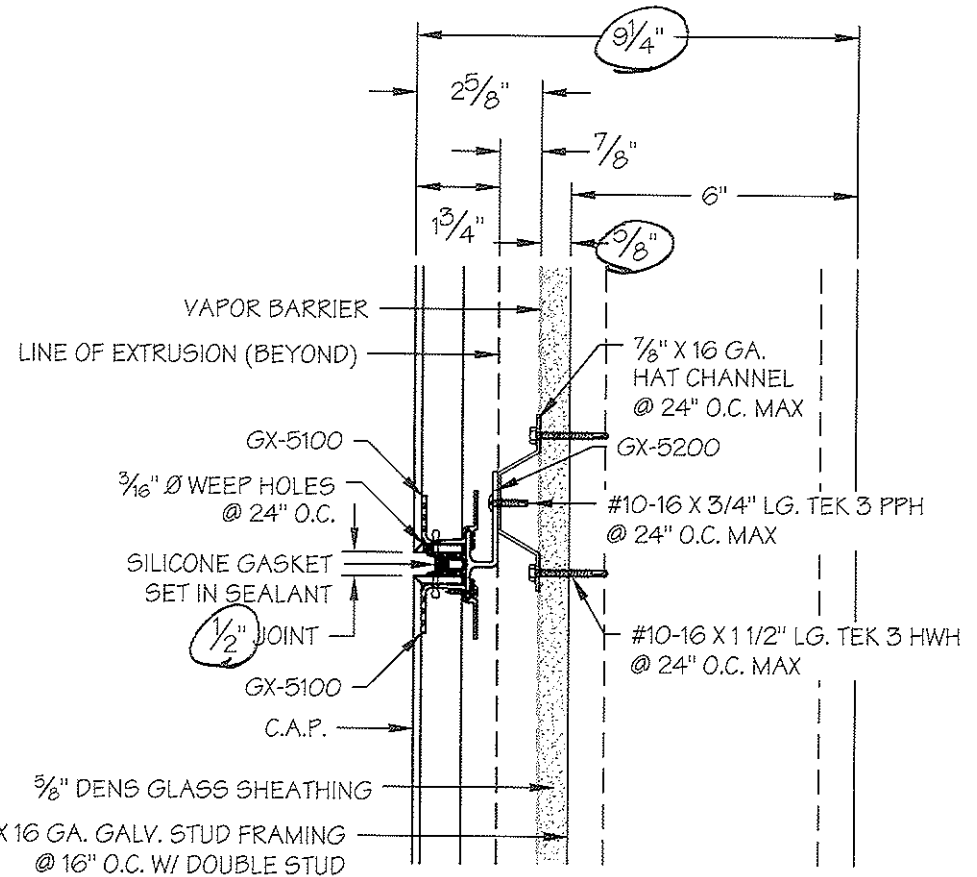

6 HORIZONTAL JOINT G-500
D-3D 3" = 1'-0" Re: N/A



Architectural Testing

Test sample complies with these details.
Deviations are noted.

Report # 91674. 02-109-44

Date 12-17-09 Tech KS

DETAILS - GASKET

BAMCO inc.

PHONE: (732) 302-0889
FAX: (732) 302-9456

30 Backland Avenue, Middlesex, NJ 08846

Project Name/Address: SYSTEM TEST 2009

General Contractor: STANDARD DETAILS

BAMCO Project No:

Drawn By: PMG

Date: 04/27/09

Scale: 3" = 1'-0"

Drawing No.

SK-
D-3D